

GeBE-COMPACT Plus

TECHNICAL INFORMATION

GPT-4672/3-(P)



Highlights at first sight:

- built-in thermal printer in robust stainless steel housing, also with presenter
- retract function for paper-saving printing and data sensible printouts
- ideal for protocol, receipt and ticket printing with text, graphics and bar codes
- for paper width 51 – 86 mm, paper thickness 70 – 200 µm and paper roll diameter up to 300 mm
- high quality print of 203 dpi with speed up to 200 mm/s
- suitable for solar operation, power supply 10 – 26 VDC

The GeBE-COMPACT Plus

The built-in thermal printer GeBE-COMPACT Plus is mounted in a stainless steel housing and is tailored for front panel or paper catch solutions. The power supply of 10 – 26 VDC also allows the solar operation.

The paper retract function back to the paper beginning directly after the cut allows paper-saving prints. The GeBe-COMPACT Plus with presenter unit can even completely confiscate a not removed printout (for example bank statements) after a programmed time. In addition, the fast printout "presenting" of the presenter unit prevents damage to printer mechanism and cutter, caused by impatient pulling when removing a ticket.

Blackmarks exactly control the printing process. The wide range of available layout commands and 8 character sizes allow attractive ticket design.

With the right paper, the printer can be used in a temperature range of -20°C to +70°C (-4°F to +158°F), also for outdoor application.

Typical application

- Protocol printing in machines
- Ticket printing in kiosk systems, e.g. for pawn
- Ticket printing in vending machines, e.g. train ticket

Drivers

The printer controller GCT-4392/-4693 will be supported by following drivers:

Windows® CE 5.0, 6.0, 7.0 and Windows® XP, 7, 8, 8.1, 10

Unix via Cups for Linux and Mac OS

Accessory details

Article number	Article description	GPT-4672	GPT-4673
Cable			
10258	Power supply cable, 6-pin for 10-36 VDC connection, length 250 mm (9.84 inch)	x	x
11352	Data round cable RS232, 5 pin, JST SHR to Sub-D, length 1,000 mm (39.37 inch)	x	x
11387	Data cable RS232, 5 pin, JST SHR - one side open, length 500 mm (19.69 inch)	x	x
12872	Data round cable USB 2.0, 5 pin, Molex to USB A, length 2,000 mm (78.74 inch)	x	x
Power supply			
13694	Power supply 24V, 6.5A with Schuko plug and power supply cable	x	x
Spare Parts			
13680	Roll holder with adjustable entry angle, paper rolls \varnothing 50 – 180 mm (1.97 – 7.09 inch)	x	
13084	Roll holder for paper rolls \varnothing 50 – 110 mm (1.97 – 4.33 inch)	x	
13306	Exit bezel with support	x	
13925	Mounting support	x	
13680	Roll holder with adjustable entry angle, paper rolls \varnothing 50 – 180 mm (1.97 – 7.09 inch)		x
13084	Roll holder for paper rolls \varnothing 50 – 110 mm (1.97 – 4.33 inch)		x
13306	Exit bezel with support		x
13925	Mounting support		x
13642	Mounting plate onto paper catch attachment GPS-085		x
13380	NPE sensor	x	x
Paper			
12993	7 years paper, roll \varnothing 70 mm (2.76 inch), core inside \varnothing 25 mm (0.98 inch), width: 59.5 \pm 0.5 mm (2.34 \pm 0.02 inch), paper thickness: approx. 80 μ m (3.15 mil), outside coated, running length: 40 m (43.75 yd)	x	
13001	7 years paper, roll \varnothing 150 mm (5.91 inch), core inside \varnothing 25 mm (0.98 inch), width: 59.5 \pm 0.5 mm (2.34 \pm 0.02 inch), paper thickness: approx. 80 μ m (3.15 mil), outside coated, running length: 210 m (229.66 yd)	x	
12785	7 years paper, roll \varnothing 70 mm (2.76 inch), core inside \varnothing 25 mm (0.98 inch), width: 82.0 \pm 0.5 mm (3.23 \pm 0.02 inch), paper thickness: approx. 80 μ m (3.15 mil), outside coated, running length: 40 m (43.75 yd)		x
13671	7 years paper, roll \varnothing 150 mm (5.91 inch), core inside \varnothing 25 mm (0.98 inch), width: 82.0 \pm 0.5 mm (3.23 \pm 0.02 inch), paper thickness: approx. 80 μ m (3.15 mil), outside coated, running length: 210 m (229.66 yd)		x

Technical drawings

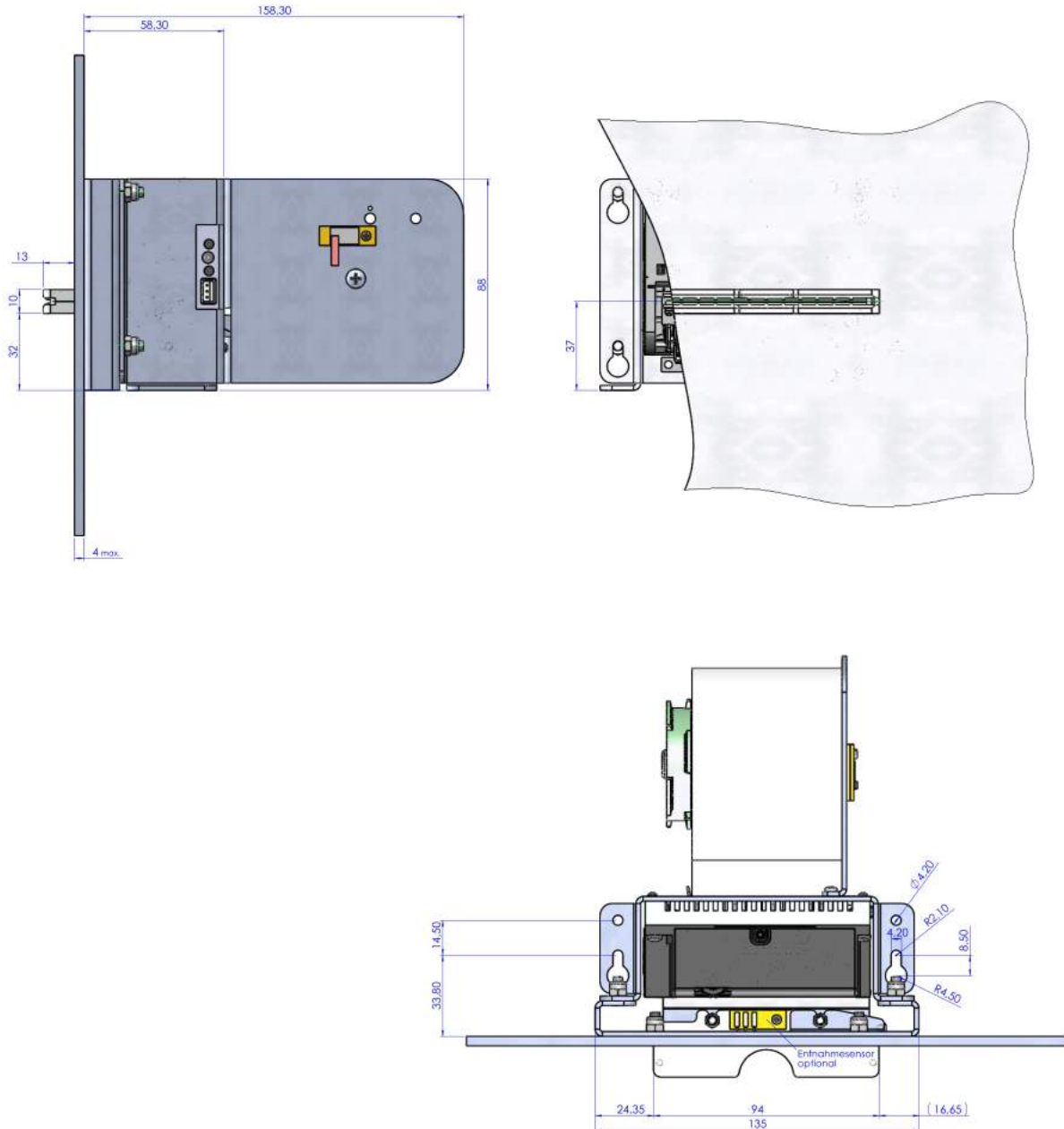

Figure 1: Dimensions GeBE-COMPACT Plus GPT-4672 (max. 60 mm paper width) in mm

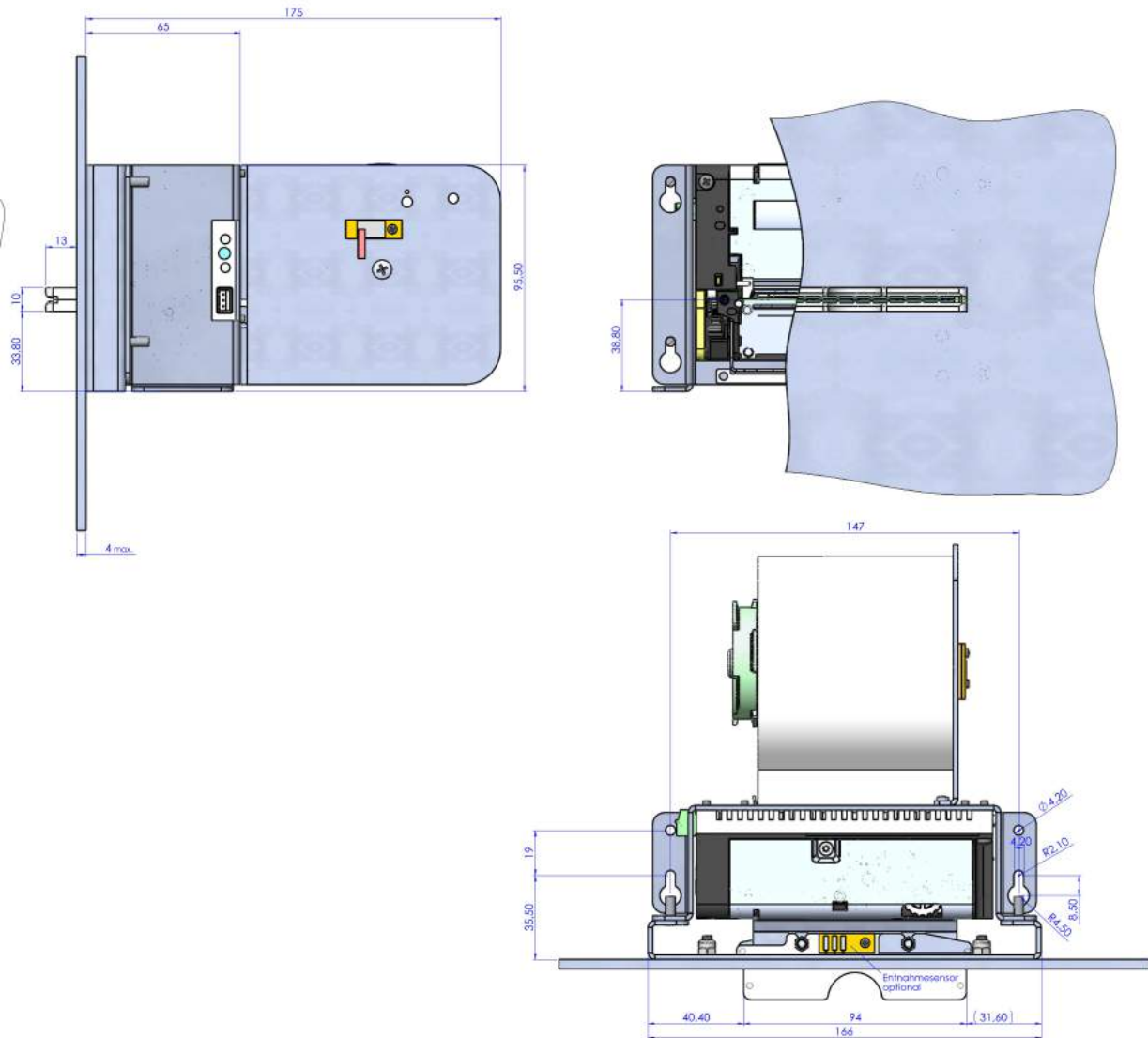

Figure 2: Dimensions GeBE-COMPACT Plus GPT-4673 (max. 82.5 mm paper width) in mm

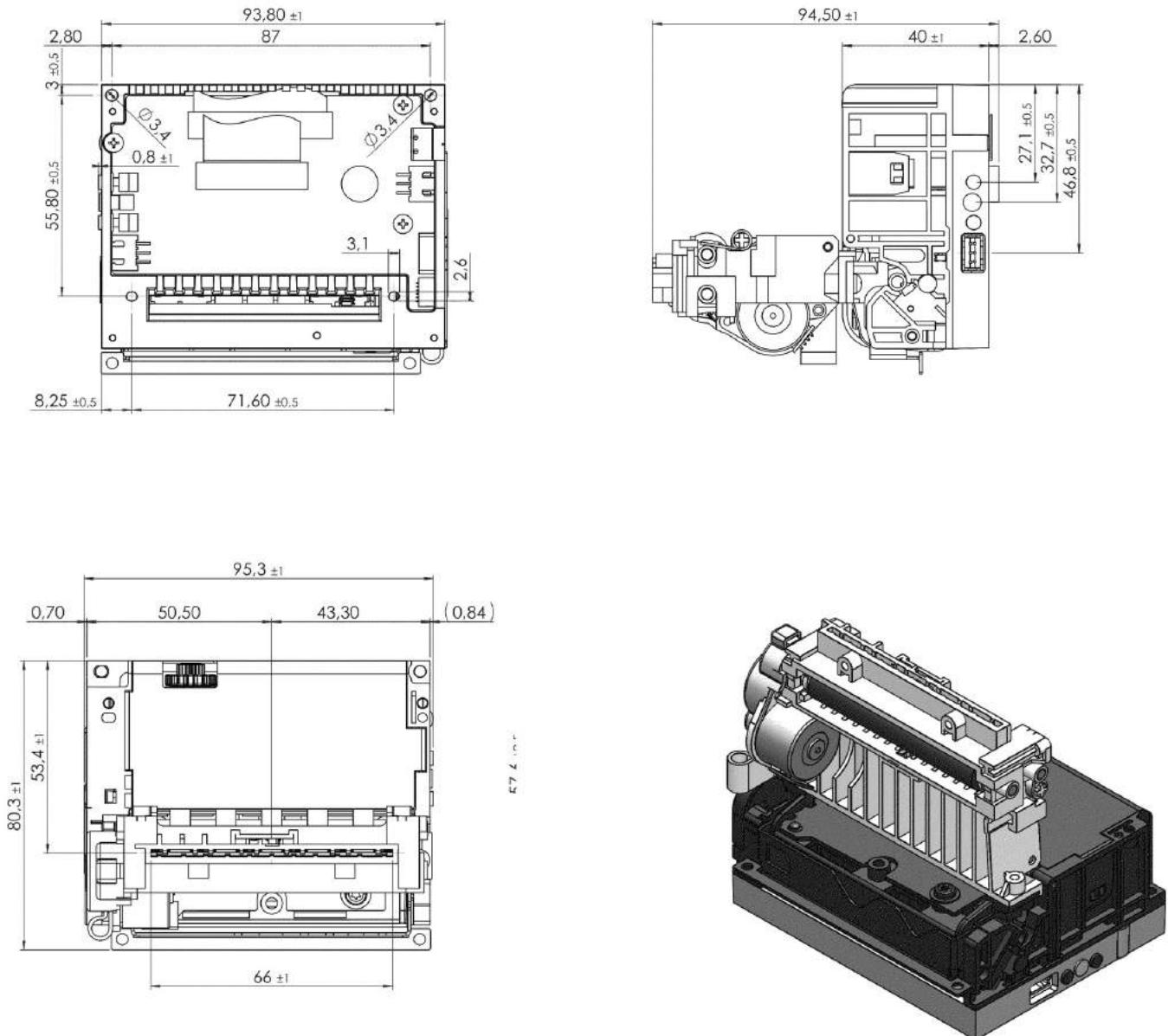

Figure 3: Dimensions GeBE-COMPACT Plus GPT-4672 (max. 60 mm paper width) with presenter in mm

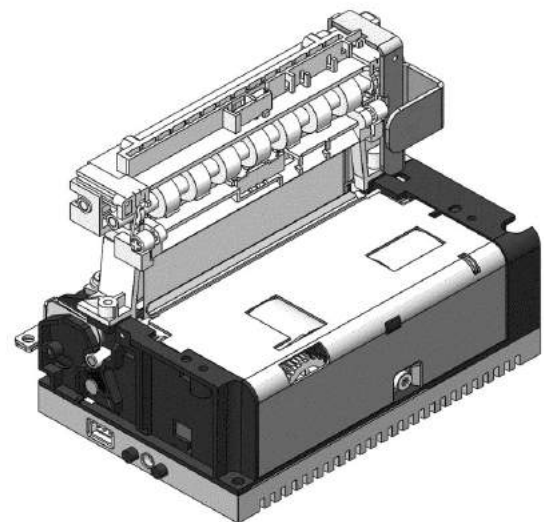
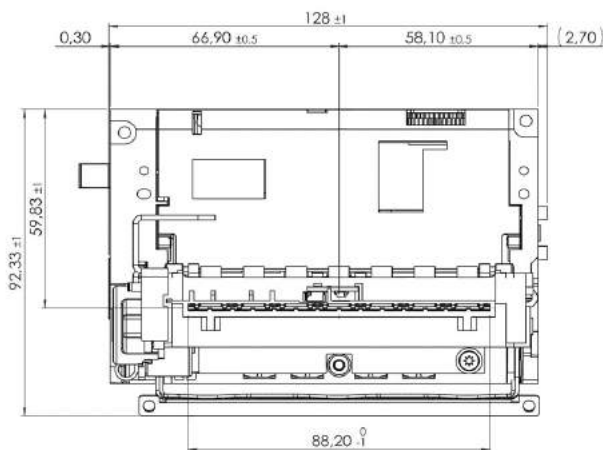
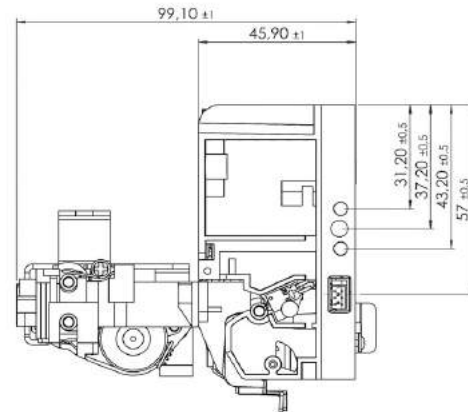
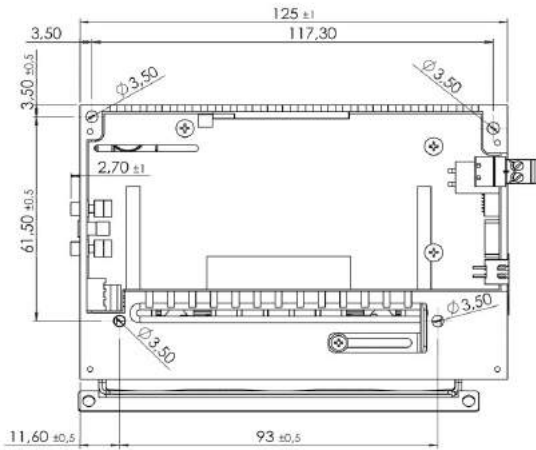

Figure 4: Dimensions GeBE-COMPACT Plus GPT-4673 (max. 82.5 mm paper width) with presenter in mm

Technical data details

	GPT-4672	GPT-4672-P	GPT-4673	GPT-4673-P
Insert paper	auto paper loading			
Print procedure	thermal direct print			
Resolution	8 dots/mm (203dpi), 448 dots/line		8 dots/mm (203dpi), 640 dots/line	
Print speed	max. 200 mm/s (7.87 inch/s), depending on printer mechanism and settings			
Paper width	51 – 60 mm (2.01 – 2.36 inch)	58 – 60 mm (2.28 – 2.36 inch)	54 – 82,5 mm (2.13 – 3.25 inch) on request: 54 – 86 mm (2.13 – 3.39 inch)	80 – 82 mm (3.15 – 3.23 inch)
Print width	56 mm (2.20 inch)		80 mm (3.15 inch)	
Paper thickness	70 – 200 µm (2.76 – 7.87 mil)	70 – 100 µm (2.76 – 3.94 mil)	70 – 200 µm (2.76 – 7.87 mil)	70 – 100 µm (2.76 – 3.94 mil)
Paper length	40 / 210 m (43.74 / 229.66 yd)			
Paper roll diameter	150 mm (5.91 inch), incl. roll holder / on request: up to 300 mm (11.81 inch)			
Supply voltage	10.8 – 26.4 VDC			
Current consumption print	adjustable via command: 3.0 – 12.0 A (peak)			
Current consumption without print	80 mA (depending on interface)			
Available interfaces	USB, RS232			
Fonts	IBMII 28, 56 characters/line, upgradeable		IBMII 36, 72 characters/line, upgradeable	
Barcode	Code 39, 2of5int, EAN13, optional on request: Code 128c, PDF 417V			
MTBF*)	100 km (62.14 mile) / 2 Mio. cuts			
Dimensions	100 x 85 x 43 mm (3.94 x 3.35 x 1.69 inch)	94 x 81 x 95 mm (3.70 x 3.19 x 3.74 inch)	113 x 93 x 50 mm (4.45 x 3.66 x 1.97 inch)	128 x 93 x 100 mm (5.04 x 3.66 x 3.94 inch)
Weight with mounting frame/tabs	approx. 550 g	approx. 547 g	approx. 837 g	approx. 1,061 g
Housing	stainless steel			
Environment**)	-20°C – +70°C (-4°F – +158°F) with specified paper			
Humidity	10 – 90 % rel. humidity, without condensation			
Storage condition	-20°C – +70°C (-4°F – +158°F) at 10 – 90 % rel. humidity, without condensation			

*) Life cycle according to mechanism testing conditions of the manufacturer with specified paper only. Please inquire. The life cycle of the print head is an averaged expectable performance and no guaranteed data. Under optimum conditions, the above listed data can be achieved using specified paper according to our documentation TI-606.

**) In case the print head reaches the maximum ambient temperature, the printer will interrupt operation until cooling down and sends an error message.

The GeBE logo is a registered trademark of GeBE Elektronik und Feinwerktechnik GmbH. All other brands named in this brochure are properties of the respective companies. The technical data given are non-committal information and do not represent any assurance of certain features. Errors and changes reserved. This technical documentation is only valid until release of a revision. Please always request the newest documentation edition.

Our terms of payment and delivery apply.

Copyright © 2017 GeBE Elektronik und Feinwerktechnik GmbH. All rights reserved.